

---

---

# PROBLEM 12-12N QUESTION

---

---

## Nucleate Boiling On A Tube Wall

---

---

A Tokamak is cooled by a single phase water flow which exits at a temperature which you will determine, and this water enters a steam generator through a large number of tubes in which parallel flow occurs (only one tube is shown in Fig. 1). Assume each tube has diameter 0.01m and all tubes together have an outside surface area of  $10^6\text{m}^2$ . Take the flow in each tube at  $\text{Re}=10^7$ .

- What outside wall temperature (see Fig. 1) would you desire to achieve on steam generator tubes for the length portion just entering the storage device? Use the boiling curve provided in Fig. 2.
- What bulk coolant temperature,  $T_B$ , within a tube entering the storage device (see Fig. 1) is necessary to achieve the wall temperature you specify in Part 2.a?

You may neglect the thermal resistance of the tube wall. In the temperature range of interest, the relevant water properties are:

$$\text{Pr} = 1.11, \quad k = 0.503 \text{ W/m K}, \quad \mu = 83.5 \times 10^{-6} \text{ Ns/m}^2, \quad c_p = 6.604 \text{ kJ/kg K}.$$

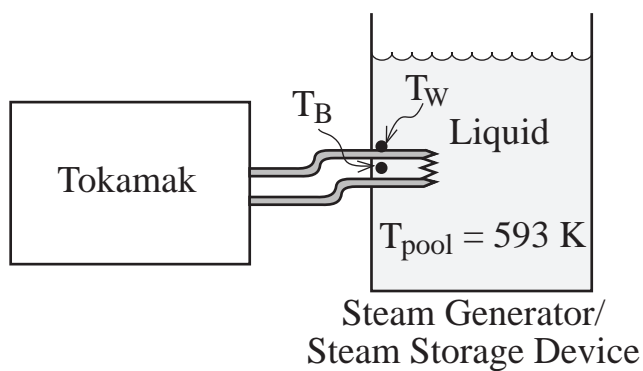

**Figure 1**

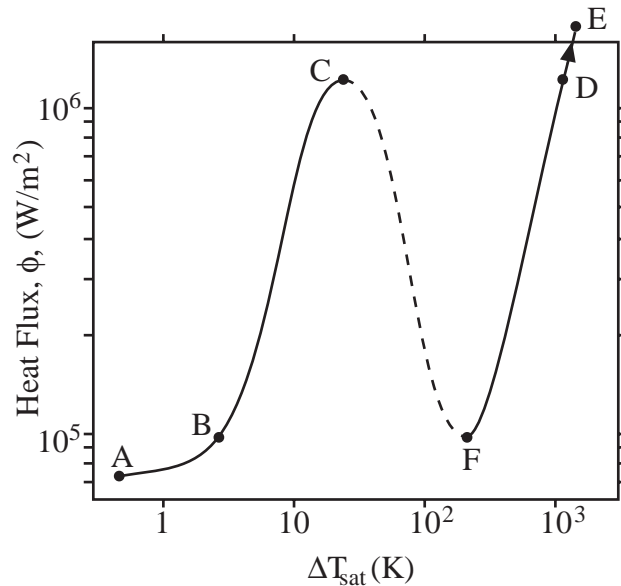

**Figure 2.** Boiling Curve.